

ORIGINAL ARTICLE

Initial experience with linear focused shockwave treatment for erectile dysfunction: a 6-month follow-up pilot study

Y Reisman¹, A Hind², A Varaneckas³ and I Motil⁴

Low-intensity shockwaves (LISW) are known to produce revascularization and have been in evaluation and in use to treat erectile dysfunction (ED). The present single-arm pilot study is aimed to assess the safety and efficacy of a dedicated shockwave device (Renova) on vasculogenic ED patients. Fifty-eight patients with mild to severe ED were treated by LISW and their erectile function was evaluated by the International Index of Erectile Function–Erectile Function Domain (IIEF–EF), Sexual Encounter Profile and Global Assessment Questions questionnaires, at baseline and at 1, 3 and 6 months post treatment. The average IIEF–EF increased significantly from 14.78 at baseline to 21.93 at 3 months post treatment and stabilized at 22.26 at 6 months post treatment. Out of 58 patients, 47 (81%) had a successful treatment. No adverse events were reported during the treatment and the follow-up duration. In conclusion, it suggests that the performance of LISW could add a new advanced treatment for ED.

International Journal of Impotence Research advance online publication, 4 December 2014; doi:10.1038/ijir.2014.41

INTRODUCTION

Vasculogenic erectile dysfunction (ED) is defined as inability to get or keep an erection firm enough for satisfying sexual intercourse and is maybe originated by diseases, such as diabetes mellitus (DM) and atherosclerotic vascular occlusive disease. Current methods for treating vasculogenic ED aim at reducing symptoms instead of reversing the source of the dysfunction, which in the majority of the patients is due to arterial or inflow disorders.¹ It has been demonstrated that shockwaves can enhance intrinsic angiogenesis and are used to treat ischemic heart disease.² Low-intensity shockwaves (LISW) have been evaluated for treating ED in both pilot and randomized sham-controlled studies. The encouraging results that were seen in these studies were the first to show the effect of LISW on ED symptoms,^{3–4} but have never been evaluated elsewhere. Recently published study conducted on rats with DM-associated ED showed that low-energy shockwave therapy (LESWT) significantly restored erectile function to levels almost similar to normal levels of controls. The therapeutic efficacy of LESWT is possibly mediated by increased recruitment of mesenchymal stem cells (MSCs) that promote the regeneration of DM-damaged erectile tissues.⁵

The present study was aimed to assess the safety and efficacy of a new dedicated shockwave device, 'Renova', which was designed to achieve substantially superior organ coverage, compared with the existing devices and hence produces positive results with a shorter protocol in a multicenter study.

SUBJECTS AND METHODS

Study protocol

This study was a multicenter open-label prospective pilot study, conducted at four sites. It was conducted in accordance with the principles of the Declaration of Helsinki of World Medical Association. Patients gave their written informed consent before participation in the study. This study consisted of a screening phase, treatment phase and a 6-month follow-up

phase. At screening phase, patients had an extensive medical and sexual history evaluation, as well as a physical examination. Inclusion criteria were heterosexual men in stable heterosexual relationship for at least 3 months, aged 20–80 years, with vascular ED (according to physician judgment) for at least 6 months, International Index of Erectile Function–Erectile Function Domain (IIEF–EF)⁶ score of 6–25 points. Recruited patients were both responders and nonresponders to phosphodiesterase type 5 inhibitors (PDE5-i). The exclusion criteria were hormonal, neurological or psychological pathology, past radical prostatectomy, any unstable medical or psychiatric condition, spinal cord injury, penile anatomical abnormalities, clinically significant chronic hematological disease, usage of antiandrogens, recovering from cancer in the past 5 years or radiotherapy in pelvic region.

At baseline and follow-up visits IIEF–EF and Sexual Encounter Profile (SEP)—questions 2 and 3 questionnaires were used.^{7–8} Global Assessment Questions⁹ (GAQ) were used at follow-ups as well. The IIEF–EF questionnaire is widely accepted as the best method to verify ED progress. It includes six questions regarding erectile function and its score range is 1–30 points. Safety was assessed at each treatment and follow-up visits, by answering questions regarding side effects and pain as part of the case report form (CRF). Patients were instructed to inform the investigators if any side effects occur.

Almost all of the patients were using PDE5-i during baseline evaluation. No PDE5-i were used 3 weeks prior to treatment, during shockwave treatment, and until the first follow-up, 1 month post treatments. Answering the questionnaires at the 3 and 6 months post-treatment follow-ups was made, whereas the patients were using PDE5-i, as was done in previously done studies.³ At all follow-up sessions, patients were instructed to return to the exact PDE5-i consumption as at baseline, as shown in Figure 1. Patients committed to avoid using any ED treatment other than PDE5-i oral medication throughout the study duration.

The treatment consisted of 4 weekly treatment sessions. During each session 3600 shocks of 0.09 mJ mm² were applied. Shocks were applied at the penis shaft at right corpus cavernosum and left corpus cavernosum, and at the crura at right crus and left crus, 900 shocks at each area. The treatment areas were the same for each session, so that at the end of the full treatment (four sessions) each area has received 3600 shocks of 0.09 mJ mm².

¹Men's Health Clinic, Amstelland Hospital, Amsterdam, The Netherlands; ²Urology and Andrology Center, Red Crescent Hospital (RCH), Ramallah, Palestine; ³Amber Clinic, Klaipėda, Lithuania and ⁴Urologicka ambulance.cz, Brno, Czech Republic. Correspondence: Dr Y Reisman, Urology, Amstelland Hospital, Laan van de Helende Meesters 8, 1187NR Amsterdam, The Netherlands.

E-mail: c.reisman@planet.nl

Received 28 December 2013; revised 10 July 2014; accepted 18 October 2014

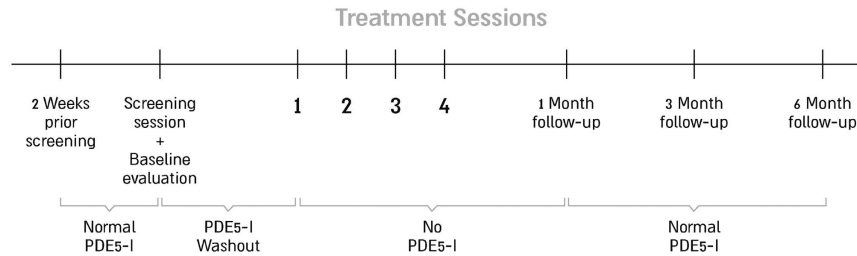

Figure 1. The use of PDE5-I throughout the study.

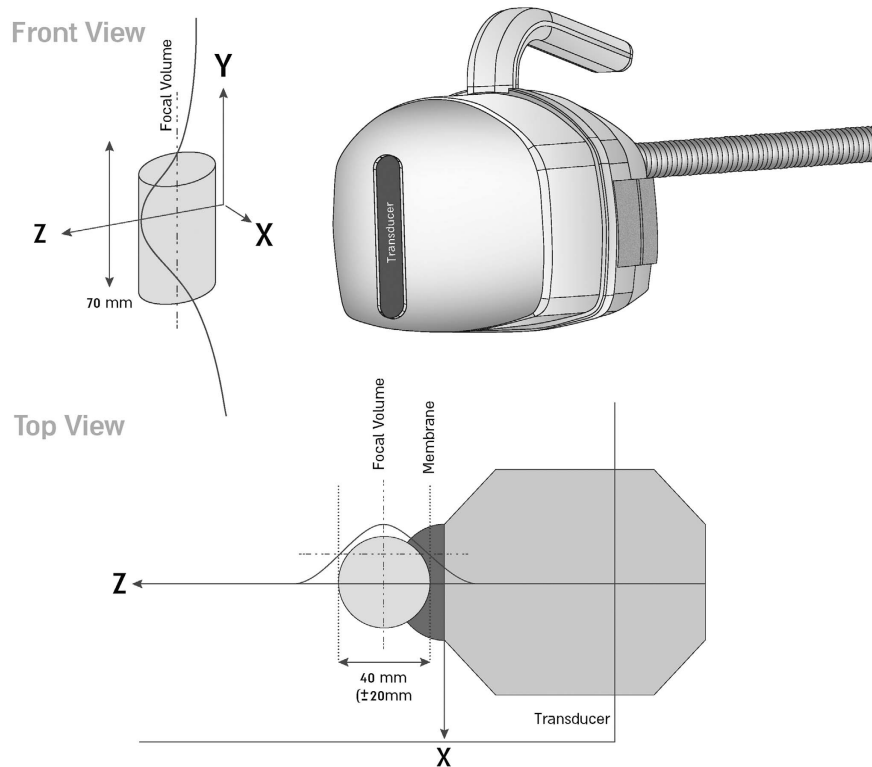

Figure 2. Qualitative view of the shockwave intensity changes.

Follow-ups were conducted at 1, 3 and 6 months post treatment and were consisted of adverse events report, IIEF-EF, SEP and GAQ questionnaires. The primary success criterion, regarding to efficacy, was defined as an increase of IIEF-EF score from baseline to the third follow-up (6 months post treatment) according to the initial ED severity: >2-point increase for mild symptoms; >5 points for moderate symptoms; and >7 points for severe symptoms.⁶

Treatment device

Renova (Direx Group) is the first dedicated shockwave system for ED. Instead of generating shockwaves that converge on a single focal point and require moving the shockwave source to multiple positions along the penis, Renova is based on linear shockwave therapy (LSWT) that enables focusing shockwaves on a 70 mm long and 10 mm width treatment area along the target organ. The shockwaves penetrate into the treated organ to a 40 mm depth and therefore their focal volume is 9.4 cm³. Figure 2 described qualitatively how shockwaves intensity changes in z axis. The prolonged shape of the transducer (Figure 3) enables effective positioning when applying to the crura by its direct contact to the groin. Renova's electromagnetic generator delivers shockwaves with a maximum energy density of 0.09 mJ mm², meaning, they deliver 10% of the pressure used for disintegrating kidney stones. Shocks are delivered at a maximum rate of 300 pulses min⁻¹ (PPM; 5 Hz), therefore, the net treatment time of a session of 3600 shocks lasts ~15 min.



Figure 3. Renova's transducer: its prolonged shape enables effective positioning when applied to the crura.

Statistical analysis

Patients' demographic variables were summarized by descriptive statistics. The average score of each questionnaire and its s.d. was calculated at baseline and at 1-, 3- and 6-month follow-up. Student's *t*-test were used at significance level of < 0.05.

RESULTS

Fifty-eight middle-aged men (mean: 56.75 ± 9.91 years, range: 33–84 years) with vasculogenic ED were recruited for this study: 20 patients were treated at Men's Health Clinic, Amstelland Hospital, Amsterdam; 17 were treated at the Urology and Andrology Center,

Red Crescent Hospital, Ramallah; 11 were treated at Amber Clinic, Klaipėda; and 10 were treated in Urologicka ambulance.cz, Brno. Patients' characteristics were similar in all sites, excluding the patients in Brno, who had a longer duration of ED and a lower success rate than the rest of the sites. The selection of patients in the Lithuanian site was made with patients who had a milder average of clinical signs.

Twenty-five patients (43.1%) suffered from cardiovascular disease, 41.4% (24 patients) had diabetes, 39.7% (23 patients) suffered from hypertension and 46.6% (27) had high cholesterol level. Fifty patients (86.2%) were PDE5-i responders. In all, 37.9% of patients were smokers, 19.0% were past smokers and 43.1% have never smoked. Table 1 describes patients' background diseases with an emphasis on some of the main risk factors for vasculogenic ED.

Patients' baseline IIEF-EF score ranged between 6 and 25 points with an average of 14.8. Table 2 summarizes the effect of low-intensity extracorporeal shockwave therapy on the IIEF-EF scores, according to the baseline ED severity.

A moderate negative Pearson correlation coefficient of -0.62 was found between the duration of ED and success of treatment. Figure 4 describes the change in the IIEF-EF score between baseline and the follow-ups at 1, 3 and 6 months post treatment, according to the duration of ED. The percentage of patients who have answered 'Yes' to questions 2 and 3 of the SEP was calculated at baseline and at 1-, 3- and 6-month follow-up and is presented in Figure 5.

The percentage of patients who have answered 'Yes' to questions 1 and 2 of the GAQ was calculated at 1-, 3- and 6-month follow-up; for question 1, the percentages were 74.14%, 82.76% and 89.66%, respectively. For question 2, the percentages at 1-, 3- and 6-month follow-up were 63.79%, 68.97% and 75.86%, respectively.

Table 1. Patients' comorbidities with an emphasis on some of the main risk factors for vasculogenic ED: cardiovascular diseases; diabetes; hypertension; and high cholesterol

Disease	Cardiovascular disease	Diabetes	Hypertension	High cholesterol
Prevalence (%)				
27.6				
19.0	✓	✓	✓	✓
10.3				✓
10.3	✓	✓		
8.6		✓		
8.6		✓		✓
6.9		✓	✓	✓
1.7	✓	✓	✓	
1.7	✓			✓
1.7		✓	✓	
1.7	✓	✓		
1.7	✓			

Table 2. The results of the IIEF-EF, before and at 6 months following low-intensity extracorporeal shockwave therapy

Baseline ED severity	Number of patients	PDE5-i responders	Baseline IIEF-EF AVG ± s.d.	IIEF-EF improvement points AVG ± s.d.	% Success	P-value
Severe	13	69.23%	8.5 ± 1.2	8.5 ± 6.3	61.54	< 0.001
Moderate	22	86.36%	13.3 ± 1.8	8.3 ± 5.1	77.27	< 0.001
Mild to moderate	18	94.44%	18.6 ± 1.5	6.8 ± 3.0	94.44	< 0.001
Mild	5	100.00%	23.6 ± 1.3	3.6 ± 0.5	100.00	< 0.001
Total	58	86.2%	14.8 ± 4.8	7.5 ± 4.7	81.03	< 0.001

Abbreviations: ED, erectile dysfunction; IIEF-EF, International Index of Erectile Function-Erectile Function Domain; PDE5-i, phosphodiesterase type 5 inhibitors. Two-tailed *t*-test was performed on the IIEF-EF scores of each group of ED severity before Renova treatment and at 6-month follow-up.

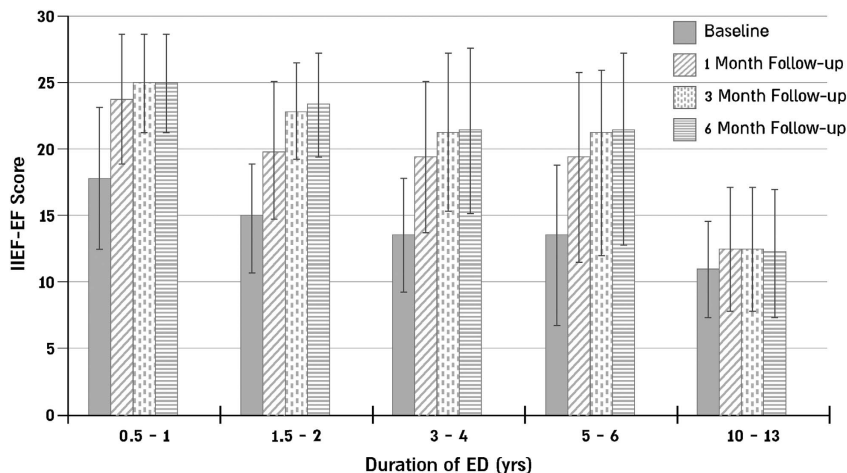

Figure 4. The change in the IIEF-EF score between baseline and the follow-ups at 1, 3 and 6 months post treatment, in accordance with the ranges of ED duration. The error bars indicate the s.d. of each group.

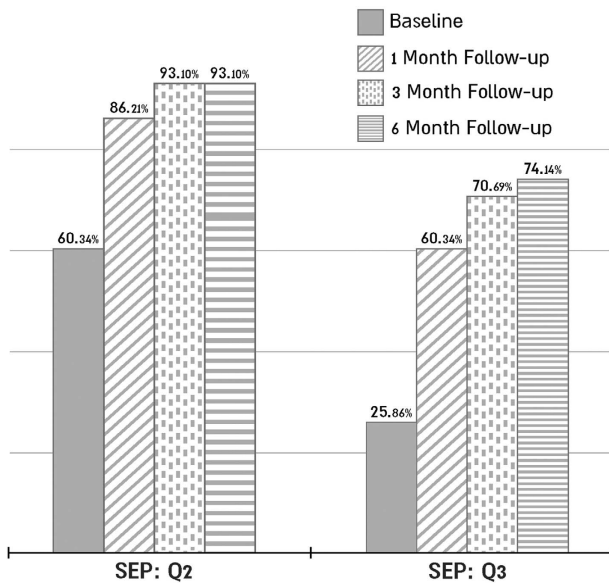

Figure 5. the average results of SEP questions 2 and 3 at the baseline and at each follow-up. The percentages represent the fraction of patients who have answered 'Yes' to each of these questions.

The difference between the IIEF-EF scores and the SEP answers, from baseline to the third follow-up was remarkable and has a statistical significance, with a P -value of < 0.001 .

LISW treatment has succeeded in $> 80\%$ of the cases (47 patients). Among the successful patients, the average IIEF-EF score increase was nine points.

When comparing diabetic patients and nondiabetic patients, the success rate of the latter group was 25% higher (70.83% and 88.24%, respectively). In all, 41.4% of patients in this study were diabetic (24 patients) and there was no significant difference between age and ED duration of the diabetic and nondiabetic patients (57.45 and 56.25 years, 2.90 and 2.96 years, respectively). This may indicate on better suitability of this treatment to nondiabetic patients.

Among the 58 patients, 4 patients stopped using PDE5-i during follow-up as they had no need for it.

No adverse events or complications were reported during and following treatment.

During the treatment period and thereafter, no use of analgesics was needed.

DISCUSSION

This study is the first study that shows a successful treatment with LISW for vascular ED in a multicenter manner, which is not connected to the previous publications and from different sites than the previous publications.³⁻⁴

When compared with previously described studies, in which PDE5-i were used, the results of this study are in line, with similar success rates.³⁻⁴

This study included patients with mild to severe ED symptoms, whereas 22.4% of patients had severe symptoms, 37.9% moderate, 31.0% mild to moderate and 8.6% mild. The average baseline IIEF-EF was 14.8 points, which represents moderate ED symptoms.

When comparing the success rate between groups of other comorbidities, no strong correlation was found. Owing to the small sample size, more research is required.

Almost 28% of the patients didn't have any of the following vascular ED risk factors: cardiovascular disease; diabetes; hypertension; and high cholesterol. The success rate of patients who

had at least one of the diseases listed above was 76.2%, whereas the success rate of patients without any of these diseases was 93.7%. There were no significant differences between the age, duration of ED and percentage of PDE5-i responders between patients with at least one of the listed disease and patients without any of these diseases (57.3 and 55.3 years, 3.0 and 2.7 years, 85.7% and 87.5%, respectively). The percentage of smokers was higher in the group of patients without any of the listed diseases (62.5%) compared with the second group (54.8%). Out of the first group, all patients who were nonsmokers (10.3% of all patients) succeeded in the treatment.

The ED duration of failed patients was on average longer than the ED duration of the whole group, with 6.4 and 2.9 years, respectively. As seen in Figure 3, the increase in IIEF-EF score decreases as the ED duration rises. Satisfactory success rates were shown in cases of ED that started up to 10 years previously, and even higher success rates were demonstrated on patients who recently noticed a decrease in erectile function. The average results are very disappointing for patients with ED for > 10 years, so it seems this treatment is not adequate for such patients whereas average results are satisfactory for patients with ED for 5–6 years or less.

A comprehensive research is required for designing a modified protocol that would be suitable for cases of longtime ED.

When considering the numerical change in IIEF-EF, only six patients (10%) have not experienced any change in their erectile function.

When reviewing the change in SEP scores, a significant increase between baseline and follow-up is noticeable. These questions can indicate directly on the patients erectile function condition, as they are referring directly to the patient's ability to perform successful intercourse.

When reviewing the individual answers for the GAQ questionnaires, it appears that 75% of the patients (44 patients) have answered 'Yes' to both questions. As these questions are intended to evaluate the treatment, these results indicate a successful treatment and support the results found with the IIEF-EF scores.

When looking at the percentage of almost 7% of patients who stopped using PDE5-i after the treatment, this could perhaps be one of the next steps in the development of this treatment option, and might be a viable option for patients who are not satisfied with the effect of PDE5-i or that these drugs are contraindicated for them.

The specifically designed device, which has a specialized transducer that is configured to reach the exact treated areas, is able to treat a bigger area than other previously used devices and therefore enables a better adjustment to the patient's body, a shorter duration of treatment and a better coverage.

This pilot study on a small number of ED patients with a relatively short follow-up shows encouraging results. Large multicenter, long-term, randomized and sham-controlled studies are needed to be able to evaluate and define those patients who respond to this type of treatment. More data are also needed with regard to the possible long-term impact of shockwaves on penile tissue. More basic research is needed to be able to understand the mechanism of action of LISW on tissues.

CONCLUSIONS

The initial results of this pilot study suggest positive outcomes of this second generation technology for treating ED with linear low-intensity shockwaves. This study with 6 months follow-up from almost 60 patients is suggestive of a positive therapeutic efficiency in the majority of the patients. Pain is tolerated by 100% of the treated patients and no side effects have been recorded, demonstrating the potential of this technology, as a treatment option for men who are not satisfied by the currently available solutions.

CONFLICT OF INTEREST

The authors declare no conflict of interest.

ACKNOWLEDGMENTS

Direx Group provided the treatment device (Renova), which generates linear focused shockwave.

REFERENCES

- 1 Stief C *et al*. Physiology and pathophysiology of men's sexual arousal and penile erection. In: Montorsi F *et al*. (eds). *Sexual Medicine Sexual Dysfunctions in Men and Women*. 3rd International Consultation on Sexual Medicine. Health Publication Ltd: Paris, 2010, pp 605–680.
- 2 Ito K, Fukumoto Y, Shimokawa H. Extracorporeal shock wave therapy as a new and non-invasive angiogenic strategy. *Tohoku J Exp Med* 2009; **219**: 1–9.
- 3 Vardi Y, Appel B, Jacob G, Massarwi O, Gruenwald I. Can low-intensity extracorporeal shockwave therapy improve erectile function? A 6-month follow-up pilot study in patients with organic erectile dysfunction. *Eur Urol* 2010; **58**: 243–248.
- 4 Vardi Y, Appel B, Kilchevsky A, Gruenwald I. Does low intensity extracorporeal shock wave therapy have a physiological effect on erectile function? Short-term results of a randomized, double-blind, sham controlled study. *J Urol* 2012; **187**: 1769–1775.
- 5 Qiu X. Effects of low-energy shockwave therapy on the erectile function and tissue of a diabetic rat model. *J Sex Med* 2013; **10**: 738–746.
- 6 Rosen RC, Allen KR, Ni X, Araujo AB. Minimal clinically important differences in the erectile function domain of the International Index of Erectile Function scale. *Eur Urol* 2011; **60**: 1010–1016.
- 7 Rosen RC, Cappelleri JC, Gendrano N 3rd. The International Index of Erectile Function (IIEF): a state-of-the-science review. *Int J Impot Res* 2002; **14**: 226–244.
- 8 Hatzichristou D *et al*. Clinical evaluation and symptoms scales in men and women with sexual dysfunction. In: Montorsi F *et al*. (eds). *Sexual Medicine Sexual Dysfunctions in Men and Women*. 3rd International Consultation on Sexual Medicine. Health Publication Ltd: Paris, 2010, pp 229–280.
- 9 Porst H *et al*. Standards for clinical trials in male sexual dysfunctions. In: Montorsi F *et al*. (eds). *Sexual Medicine Sexual Dysfunctions in Men and Women*. 3rd International Consultation on Sexual Medicine. Health Publication Ltd: Paris, 2010, pp 567–603.